

SERIES 46

EMI/RFI Shrink Boot Bandstrap Adapter Environmental, Screened

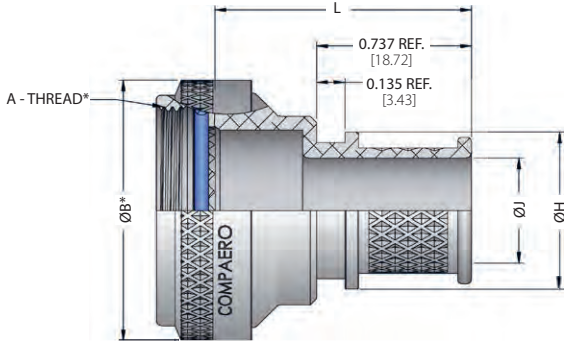

Angle 1 - Straight Rotatable Coupling



Angle 4 - 45 Degree

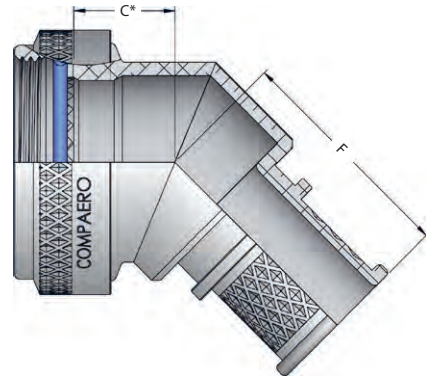

Angle 8 - 90 Degree

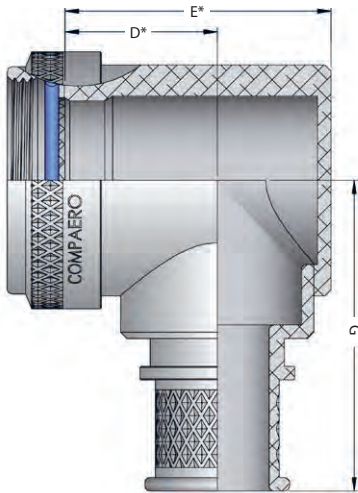

Angle 9 - 90 Degree Miter Cut

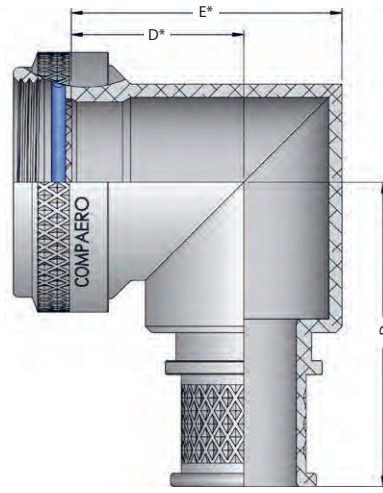

CP A 46 1 W D - 12 03 - B1 - VG0 - 8

Compaero Identifier

Connector Interface

See page 6 for details

Series Identifier

Angle

Material & Finish

See page 7 for details

Coupling Ring Option

Omit for standard rotatable

D - Direct coupling

E - Seat-lock (Non-detent, self locking)

S - Self locking (Detent, ratchet style)

T - Safety wire holes

W - Wrench flats

See page 8 for details

Length

See dimension L - In 0.25 Inch increments

Omit for 1.25" (Standard) & angled parts

Shrink Boot Option

Omit for no boot - See website for details

Banding Option

Omit for none

S - Constant Force Spring Band

B - Stamped Buckle Band (flat)

B1 - Stamped Buckle Band (pre-coiled)

M - Stamped Buckle Mini Band (flat)

M1 - Stamped Buckle Mini Band (pre-coiled)

See page 40 for details

Cable Entry

See table 2

Shell Size

See table 1

* Refer to interface tables in pages 43 & 44

inches [millimeters]

THIS DRAWING IS THE PROPERTY OF COMPAERO INDIA PVT. LTD. AND MUST NOT BE USED FOR COMMERCIAL PURPOSES WITHOUT WRITTEN CONSENT OF THE COMPANY. DRAWING CORRECT AT TIME OF PUBLISHING.

SERIES 46

EMI/RFI Shrink Boot Bandstrap Adapter Environmental, Screened



Table 1 Shell Size

SHELL SIZE	F MAX	G MAX
	in mm	in mm
08/09	1.02 25.9	1.29 32.8
10/11	1.04 26.4	1.35 34.3
12/13	1.07 27.2	1.42 36.1
14/15	1.10 27.9	1.48 37.6
16/17	1.12 28.4	1.54 39.1
18/19	1.13 28.7	1.57 39.9
20/21	1.16 29.5	1.63 41.4
22/23	1.19 30.2	1.70 43.2
24/25	1.21 30.7	1.76 44.7
28/29	1.24 31.5	1.82 46.2
32/33	1.29 32.8	1.95 49.5
36	1.33 33.8	2.04 51.8
40	1.38 35.1	2.17 55.1
44	1.43 36.3	2.29 58.2
48	1.48 37.6	2.42 61.5
61	1.20 30.5	1.73 43.9

Table 2 Entry Size

ENTRY SIZE	ØH MAX	ØJ
	in mm	in mm
01	0.392 10.0	0.125 3.2
31	0.455 11.5	0.188 4.8
02	0.517 13.1	0.250 6.4
32	0.580 14.7	0.313 7.9
03	0.642 16.3	0.375 9.5
33	0.705 17.9	0.438 11.1
04	0.767 19.5	0.500 12.7
34	0.830 21.1	0.563 14.3
05	0.892 22.7	0.625 15.9
35	0.955 24.2	0.688 17.5
06	1.017 25.8	0.750 19.1
36	1.080 27.4	0.813 20.6
07	1.142 29.0	0.875 22.2
37	1.205 30.6	0.938 23.8
08	1.267 32.2	1.000 25.4
38	1.330 33.8	1.063 27.0
09	1.392 35.4	1.125 28.6
10	1.517 38.5	1.250 31.8
11	1.642 41.7	1.375 34.9
12	1.767 44.9	1.500 38.1
13	1.892 48.1	1.625 41.3
14	2.017 51.2	1.750 44.5
15	2.142 54.4	1.875 47.6
16	2.267 57.6	2.000 50.8

inches millimeters
Tolerance ±0.01±0.25